

MS 152/7 P

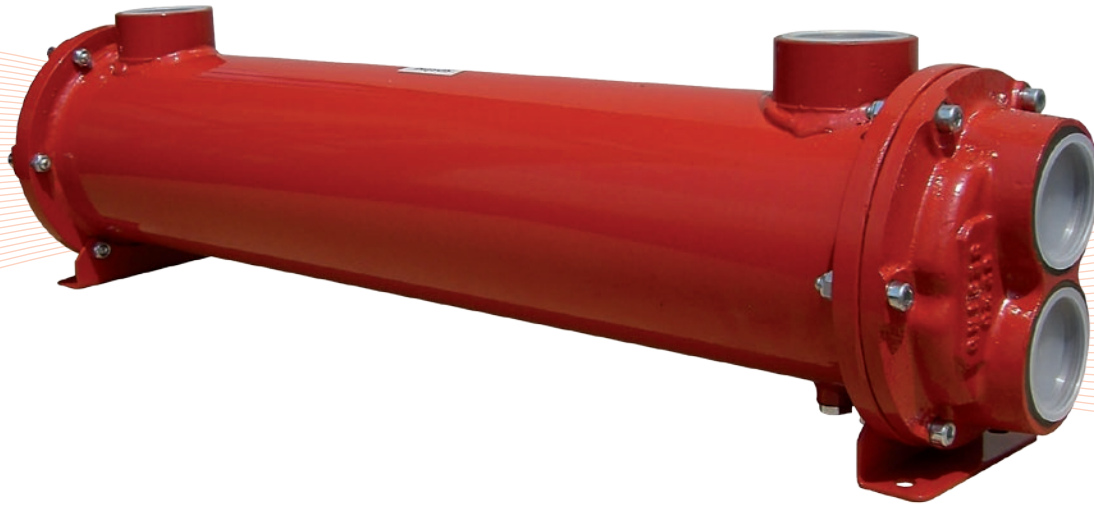

CONSTRUCTION MATERIALS		
SHELL	TUBES	END COVERS
CARBON STEEL*	COPPER*	CAST IRON*
STAINLESS STEEL	STAINLESS STEEL	STAINLESS STEEL
BRASS	CuNi (water sea)	BRONZE

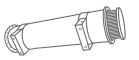

- Dimensions and technical characteristics are not binding

*standard

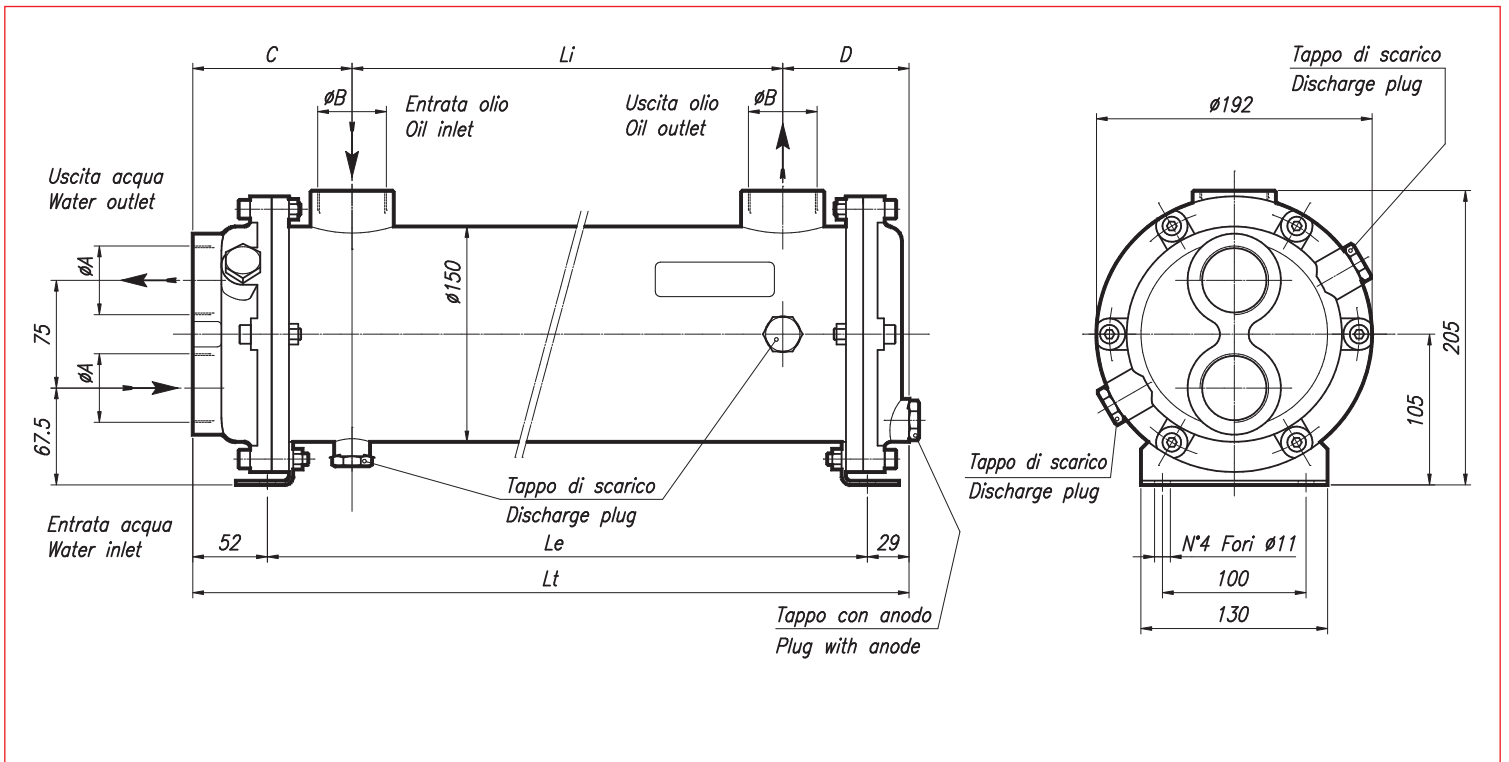

TYPE	CODE	OIL FLOW l/min	WATER FLOW l/min	kW MIN water flow		kW MAX water flow		WEIGHT kg	DIMENSIONS						
				ΔT_m 25° C		ΔT_m 25° C			ϕA	ϕB	C	D	Li	Le	Lt
MS 152/7 P1	2SC152/7P1	40-120	40-160	4,5	6,9	5,1	8,3	17	1" gas	3/4" gas	101	78	80	178	259
MS 152/7 P2	2SC152/7P2	80-200	40-160	8	10	10	15	21	1" gas	1" gas	111	88	150	268	349
MS 152/7 P3	2SC152/7P3	130-300	40-160	15	19	23	33	26,5	1 1/2" gas	1 1/2" gas	111	88	300	418	499
MS 152/7 P4	2SC152/7P4	150-330	40-160	10	20	15	30	32	2" gas	2" gas	121	98	430	568	649
MS 152/7 P5	2SC152/7P5	200-400	40-160	30	42	45	65	38,5	2" gas	2" gas	121	98	590	728	809
MS 152/7 P6	2SC152/7P6	100-300	40-160	21	42	35	65	44	2" gas	2" gas	121	98	720	858	939
MS 152/7 P7	2SC152/7P7	250-500	40-160	39	47	69	98	54	2" gas	2" gas	121	98	970	1108	1189
MS 152/7 P8	2SC152/7P8	250-500	40-160	48	55	88	118	62	2" gas	2" gas	121	98	1170	1308	1389
MS 152/7 P9	2SC152/7P9	250-500	40-160	55	70	97	130	70	2" gas	2" gas	121	98	1370	1508	1589

MS 152/7 P

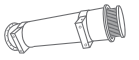

WATER FLOW RATE:

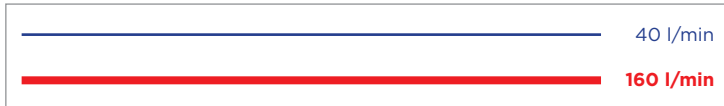

P1 P2 P3

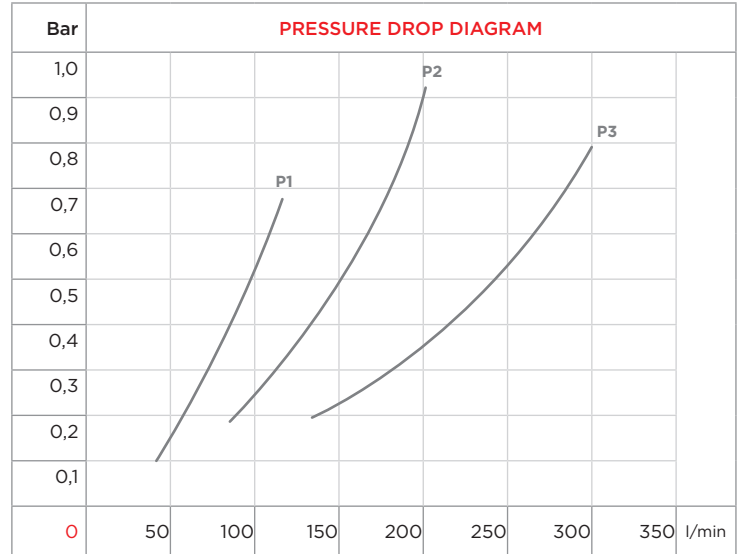
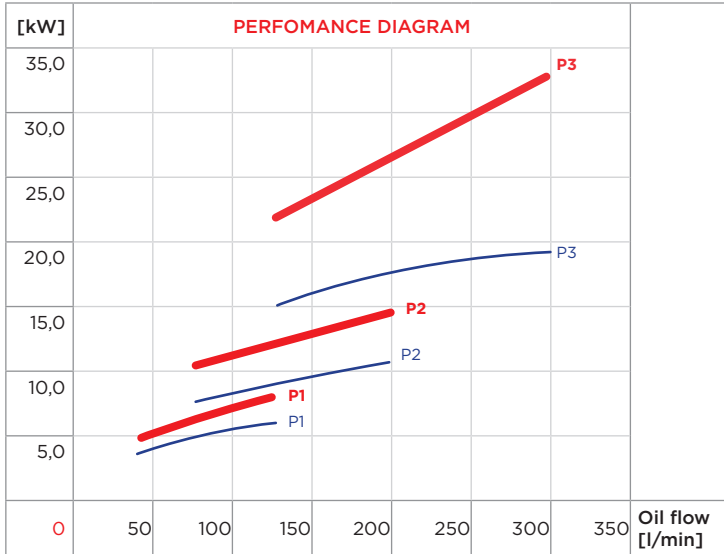

P4 P5 P6

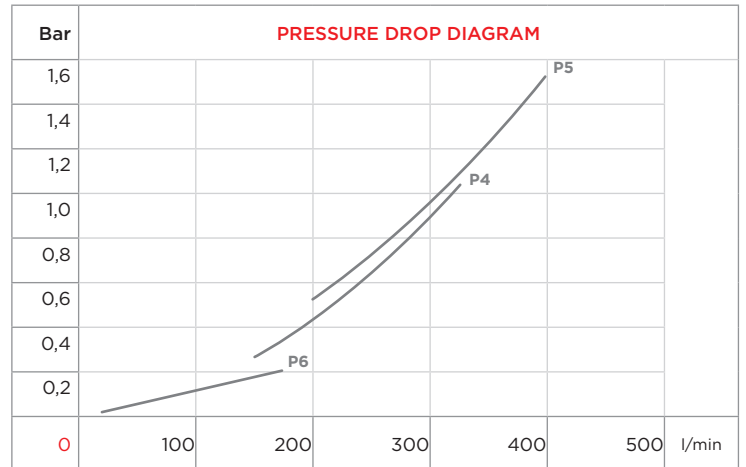
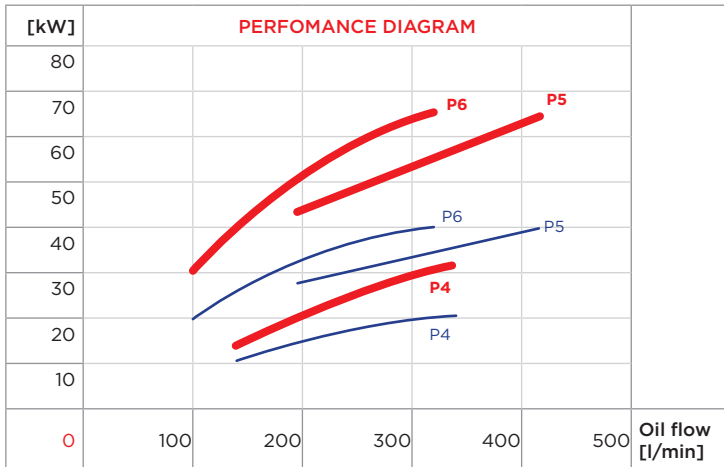

P7 P8 P9

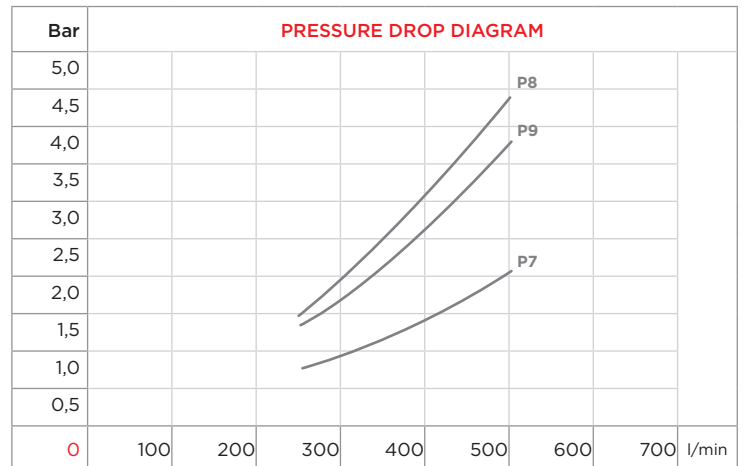
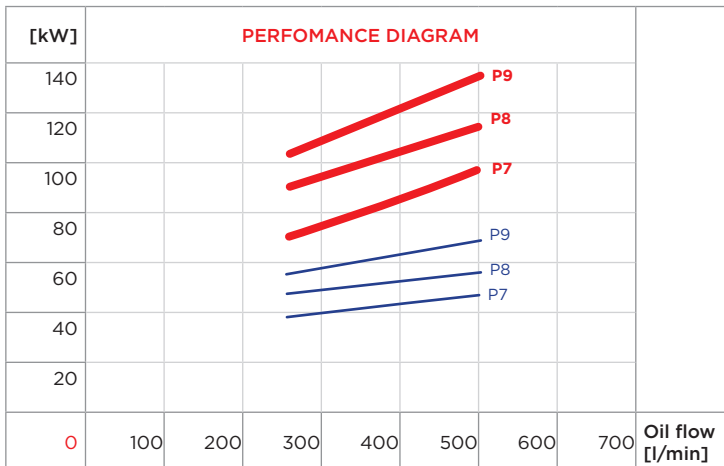

CORRECTION FACTOR							
ΔT_m	10	15	20	25	30	35	40
f	2,5	1,67	1,25	1	0,83	0,71	0,63

CORRECTION FACTOR							
cSt	22	30	46	68	100	150	220
f	0,4	0,6	1	1,5	2,3	3,3	4,6